

MZ40V Driven Toolholders - Enhanced Program

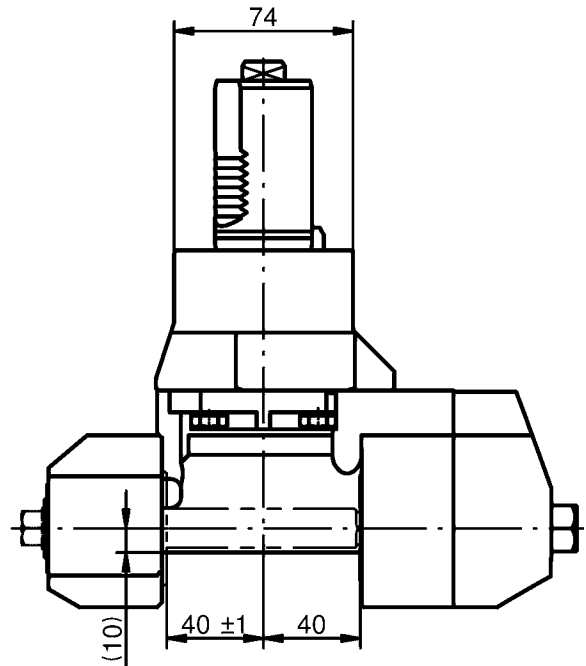

Gear hobbing unit
External coolant supply

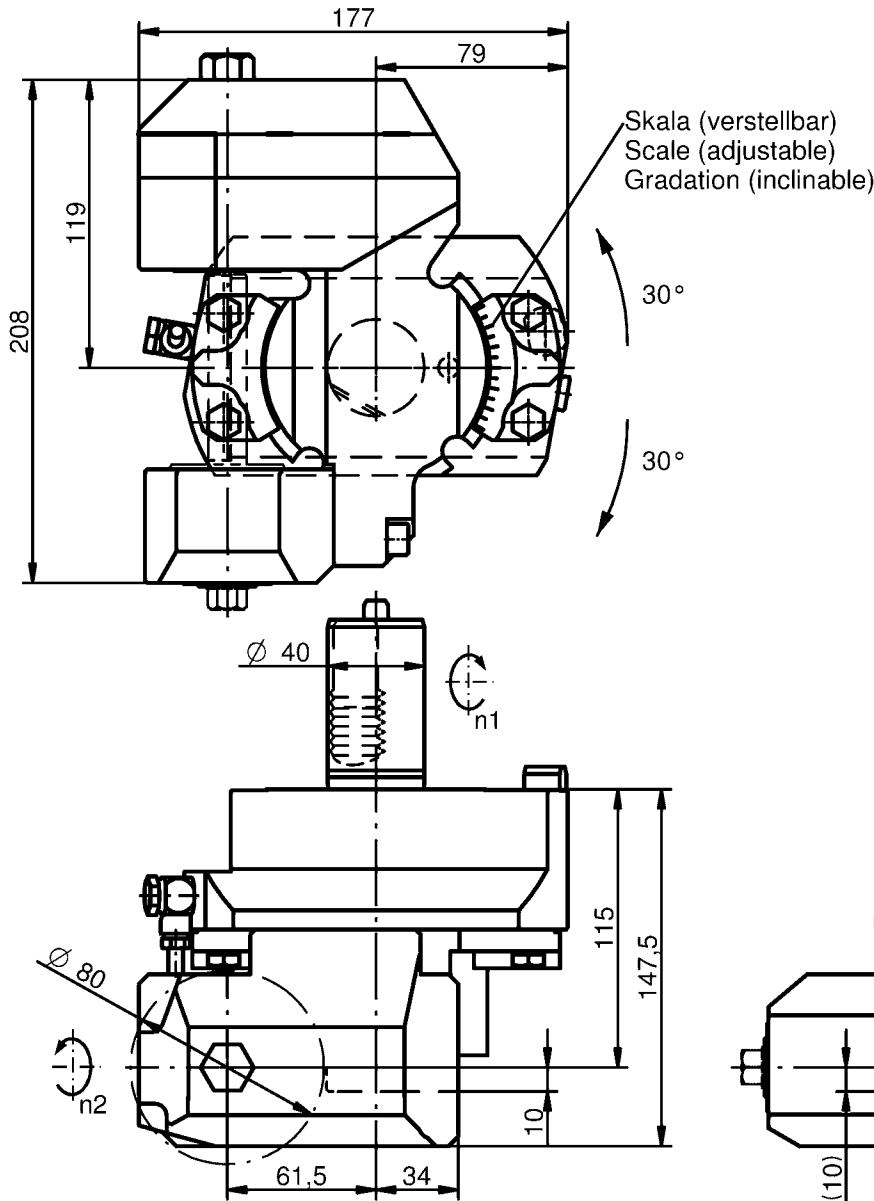
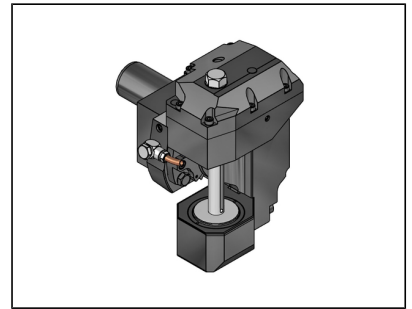

Item No.	Tool Clamping	Tool-Ø	Torque(Nm)	n2 max(rpm)	i (n1:n2)
411500042-40	Type 16-1	80	60	6,000	1:1

Accessories
(not included)



00675000926
Wrench set



1600x161
Interchangeable milling arbors
type 16x1



110587_
Sine bar